

### Self-aligning ball bearings, cylindrical and tapered bore

Principal dimensions			Basic load ratings		Fatigue load limit Pu	Speed ratings		Mass	Designation
d	D	B	dynamic	static		Reference speed	Limiting speed		
mm			kN	C0	kN	r/min		kg	-
25	52	18	14,3	4	0,21	-	9000	0,16	2205 E-2RS1KTN9

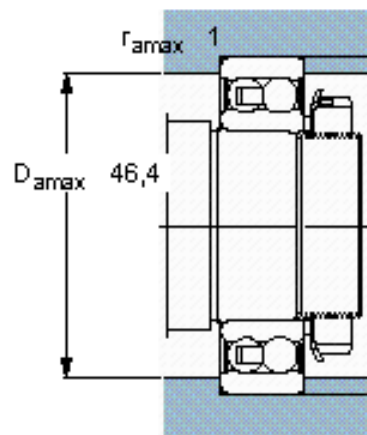
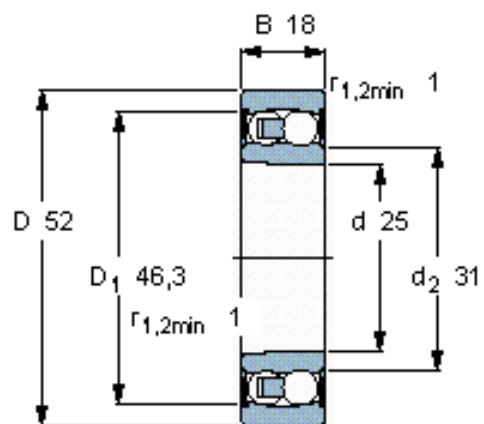

#### Calculation factors

$e$  0,28  
 $Y_1$  2,2  
 $Y_2$  3,5  
 $Y_0$  2,5