

### Taper roller bearings, single row

Principal dimensions			Basic load ratings		Fatigue load limit Pu	Speed ratings		Mass	Designation
d	D	T	dynamic	static		Reference speed	Limiting speed		
mm			kN		kN	r/min		kg	* - SKF Explorer bearing
180	320	57	583	815	80	1500	2000	20,0	30236 J2

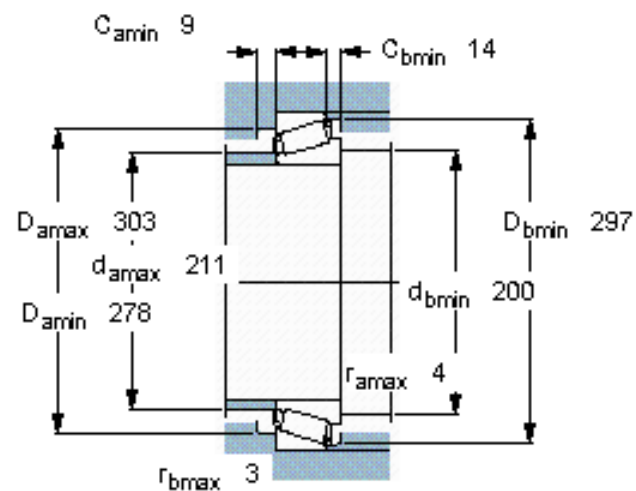
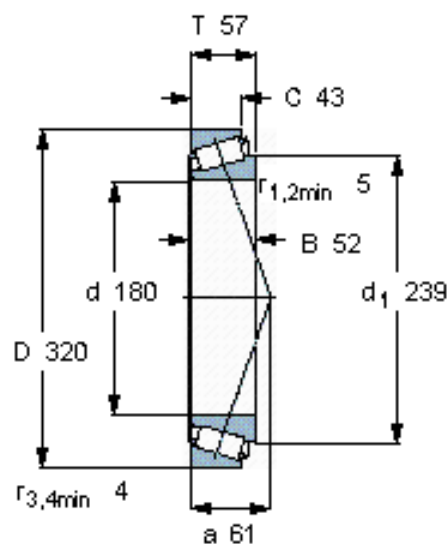

#### Calculation factors

e 0,44

Y 1,35

$Y_0$  0,8