

Taper roller bearings, single row

Principal dimensions			Basic load ratings		Fatigue load limit Pu	Speed ratings		Mass	Designation
d	D	T	dynamic	static		Reference speed	Limiting speed		
mm			kN		kN	r/min		kg	* - SKF Explorer bearing
40	90	25,25	85	81,5	9,5	5600	7500	0,72	31308 J2/QCL7C *

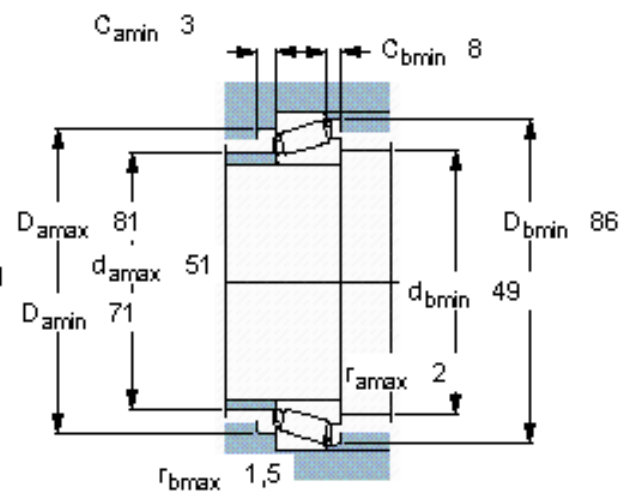
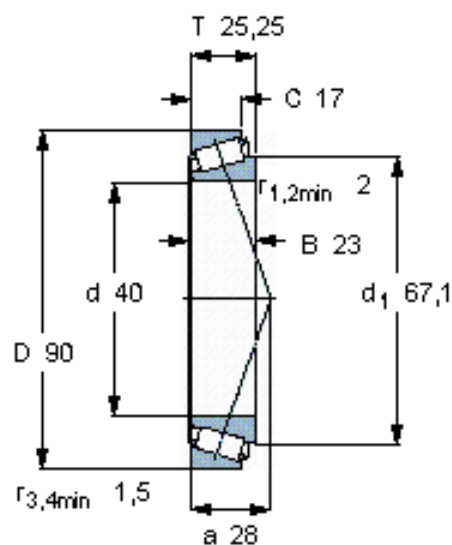

Calculation factors

e 0,83

Y 0,72

$Y_0 0,4$