

Spherical roller bearings, cylindrical and tapered bore

| Principal dimensions | | | Basic load ratings | | Fatigue load limit Pu | Speed ratings | | Mass | Designation |
|----------------------|-----|-----|--------------------|--------|--------------------------|-----------------|----------------|------|-----------------|
| d | D | B | dynamic | static | | Reference speed | Limiting speed | | |
| mm | | | kN | | kN | r/min | | kg | - |
| 420 | 620 | 150 | 3400 | 6000 | 415 | 600 | 1100 | 150 | 23084 CAK/W33 * |

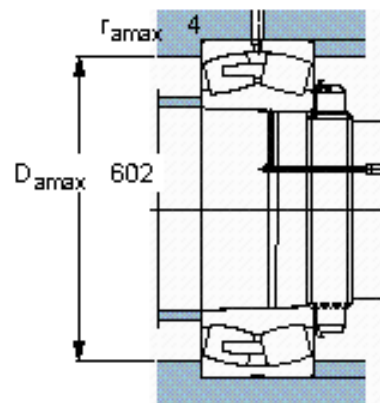
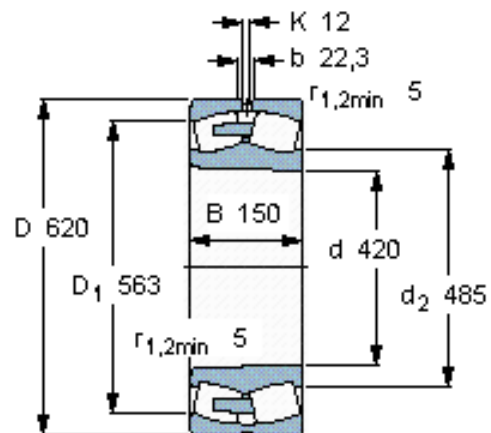

Calculation factors

e 0,22
 Y_1 3
 Y_2 4,6
 Y_0 2,8